

Manufacturer's Warranty Statement

The manufacturer warrants organ blower type(s)

LVM2....., 60 Hz, 1 ph.A.C., 120 V

for a period of three years from the date of purchase providing the following installation and maintenance guidelines are observed:

1. The sleeve-bearings of the organ blowers are **filled up with 100 ml of oil** Shell Tellus S2 MX and **never need to be refilled**. This oil quantity adequately lubricates the bearings for 20 000 hours of operation.
The organ blower does not require further lubrication!
2. The organ blowers must be transported **standing on their feet** and they **shall not be inverted** even during installation.
3. Electrical service shall be connected to the blower motor per the attached wiring diagram. The **motors** should be **protected against over-heating**.
4. The organ blowers must be mounted with **elastic fastening: connecting flange**.
5. **WARRANTY IS VOID** if motor failure is caused by improper or inadequate lubrication, incorrect, or incorrectly installed electrical service, if deployed in an applications other than its intended use, mishandled, or damaged due to natural disaster beyond the manufacturer's control. The capacitor is excluded from warranty coverage.

Defective motors covered under the manufacturer's warranty should be turned to the authorized distributor for warranty replacement. Shipping and handling charges are not included.

Date of sale:

Serial No.:

Manufacturer: KÖNYVES és FIA KFT

Hungary 9061 VÁMOSSZABADI, Hild József u. 5.

Mobil: 011 36/30 747 36 83

e-mail: konyves@orgonafuvo.hu

www.organblower.com

WIRING DIAGRAM OF ORGAN BLOWERS OF TYPE LVM2

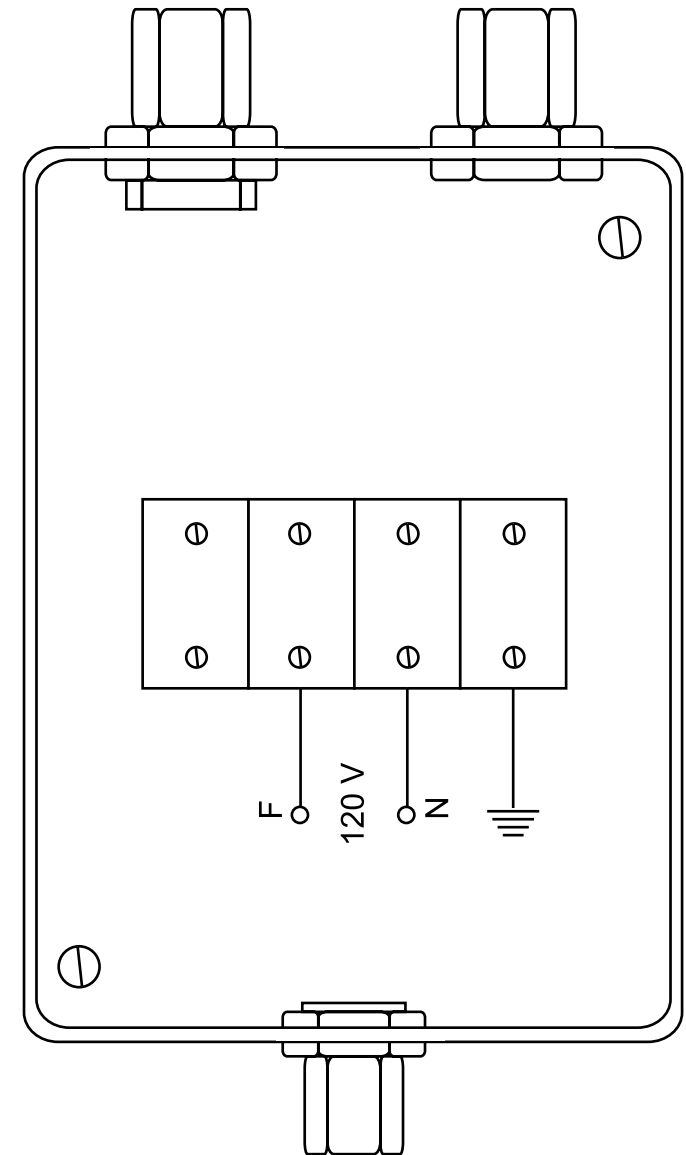

**capacitor:
blue,
brown**

**coil wire:
black
ground:
green
yellow**

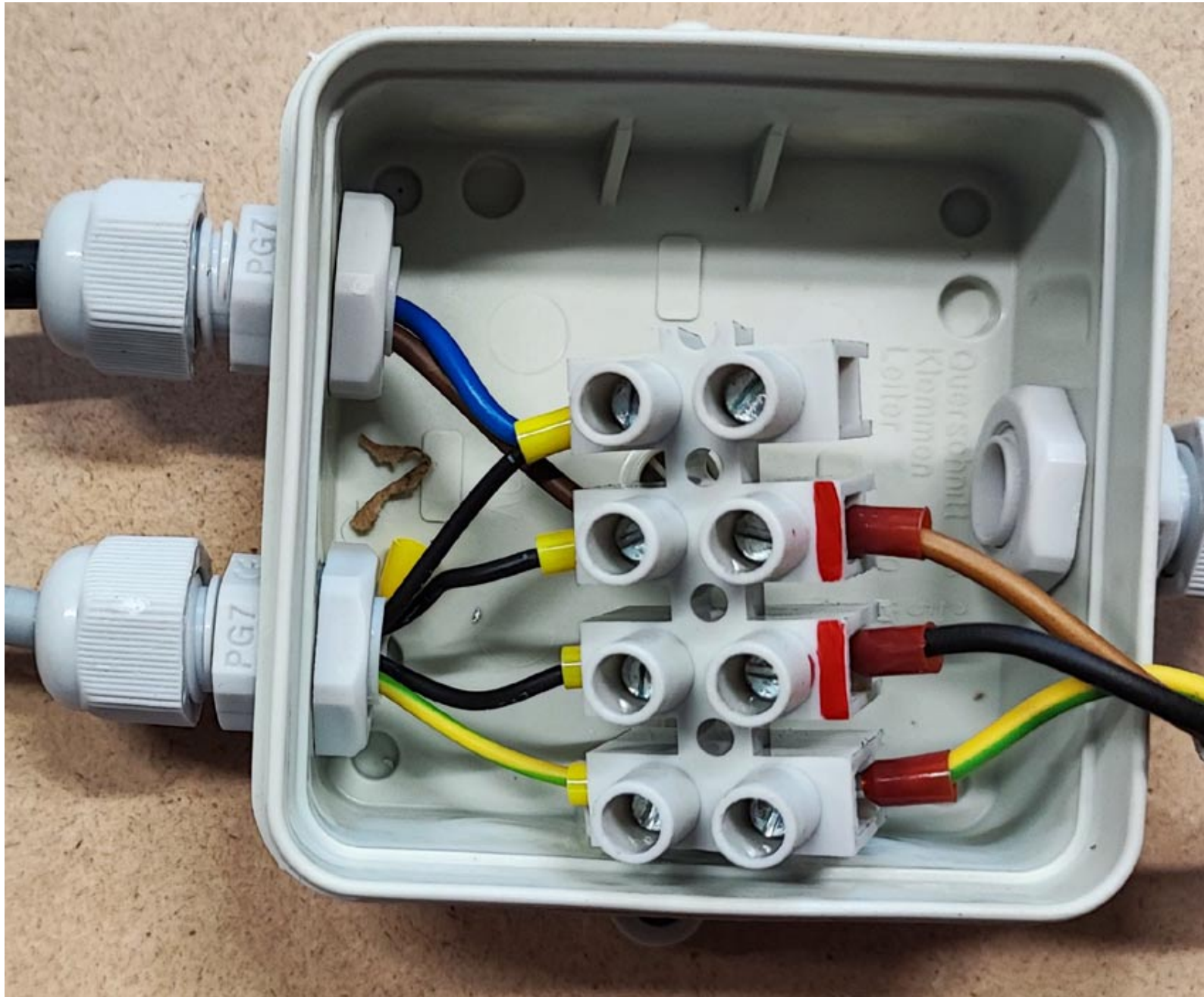

**1 phase:
brown**

**1 phase:
black**

**ground:
green
yellow**